

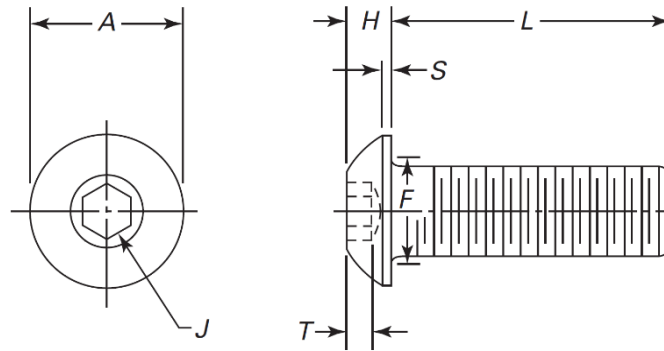

# Button Head Cap Screw



+1 (610) 904-8616  
[sales@nickel-systems.com](mailto:sales@nickel-systems.com)  
[www.nickel-systems.com](http://www.nickel-systems.com)



Slight flat and/or  
 countersink  
 permissible

ASME B18.3 - 2012

Nominal Size (Basic Screw Diameter)	A		H		S	J	T	F		L			
	Head Diameter		Head Height					Head Side Height (Ref.)	Nominal Hexagon Socket Size		Minimum Key Engagement	Fillet Extension	
	Max.	Min.	Max.	Min.								Max.	Min.
0	0.0600	0.114	0.104	0.032	0.026	0.010	...	0.035	0.020	0.080	0.070	0.50	
1	0.0730	0.139	0.129	0.039	0.033	0.010	...	0.050	0.028	0.093	0.083	0.50	
2	0.0860	0.164	0.154	0.046	0.038	0.010	...	0.050	0.028	0.106	0.096	0.50	
3	0.0990	0.188	0.176	0.052	0.044	0.010	1/16	0.062	0.035	0.119	0.109	0.50	
4	0.1120	0.213	0.201	0.059	0.051	0.015	1/16	0.062	0.035	0.132	0.122	0.50	
5	0.1250	0.238	0.226	0.066	0.058	0.015	5/64	0.078	0.044	0.145	0.135	0.50	
6	0.1380	0.262	0.250	0.073	0.063	0.015	5/64	0.078	0.044	0.158	0.148	0.63	
8	0.1640	0.312	0.298	0.087	0.077	0.015	3/32	0.094	0.052	0.194	0.184	0.75	
10	0.1900	0.361	0.347	0.101	0.091	0.020	1/8	0.125	0.070	0.220	0.210	1.00	
1/4	0.2500	0.437	0.419	0.132	0.122	0.031	5/32	0.156	0.087	0.290	0.280	1.00	
5/16	0.3125	0.547	0.527	0.166	0.152	0.031	3/16	0.188	0.105	0.353	0.343	1.00	
3/8	0.3750	0.656	0.636	0.199	0.185	0.031	7/32	0.219	0.122	0.415	0.405	1.25	
7/16	0.4375	0.765	0.746	0.231	0.218	0.031	1/4	0.250	0.140	0.478	0.468	1.50	
1/2	0.5000	0.875	0.851	0.265	0.245	0.046	5/16	0.312	0.175	0.560	0.540	2.00	
5/8	0.6250	1.000	0.970	0.331	0.311	0.062	3/8	0.375	0.210	0.685	0.665	2.00	
3/4	0.7500	1.125	1.105	0.375	0.355	0.062	7/16	0.437	0.245	0.740	0.720	2.50	